

2020



Explorer / Aviator
Hybrid and Plug-in Hybrid

HV BATTERY REMOVAL GUIDE FOR DISMANTLERS



SECTION 1: Battery Removal Guide

Table of Contents

Contents	PAGE
Battery Removal Guide	1-2
High Voltage Battery Depowering	1-2
High Voltage Battery Depowering using FDRS	1-3
Manual De-Energizing	1-4
HEV — Battery Removal	1-6
PHEV — Battery Removal	1-12
SPECIAL NOTE TO DISMANTLERS AND SALVAGE YARDS	1-23

Battery Removal Guide

Battery Removal Guide

High Voltage Battery Depowering

 **WARNING:**

THE HIGH-VOLTAGE SYSTEM MAY RETAIN A DANGEROUS LEVEL OF VOLTAGE FOR A SHORT TIME AFTER THE SERVICE DISCONNECT HAS BEEN OPENED. WAIT 5 MINUTES FOR THE VOLTAGE TO DISSIPATE BEFORE BEGINNING SERVICE. FAILURE TO FOLLOW THIS INSTRUCTION MAY RESULT IN SERIOUS PERSONAL INJURY OR DEATH.

 **WARNING:**

REMOVING THE BATTERY HIGH VOLTAGE SERVICE DISCONNECT DOES NOT DISSIPATE VOLTAGE INSIDE THE BATTERY PACK. THE BATTERY PACK REMAINS LIVE AND DANGEROUS. CONTACT WITH THE HIGH VOLTAGE BATTERY PACK INTERNALS MAY RESULT IN SERIOUS PERSONAL INJURY OR DEATH.

 **WARNING:**

ELECTRIC VEHICLES DAMAGED BY A CRASH MAY HAVE COMPROMISED HIGH VOLTAGE SAFETY SYSTEMS AND PRESENT A POTENTIAL HIGH VOLTAGE ELECTRICAL SHOCK HAZARD. EXERCISE CAUTION AND WEAR APPROPRIATE PERSONAL PROTECTIVE EQUIPMENT (PPE) INCLUDING HIGH VOLTAGE SAFETY GLOVES AND BOOTS. REMOVE ALL METALLIC JEWELRY, INCLUDING WATCHES AND RINGS. ISOLATE THE HIGH VOLTAGE SYSTEM AS DIRECTED BY THE FORD EMERGENCY RESPONSE GUIDE FOR THE VEHICLE. FAILURE TO FOLLOW THESE INSTRUCTIONS MAY RESULT IN SERIOUS PERSONAL INJURY OR DEATH.

 **WARNING:**

TO PREVENT THE RISK OF HIGH-VOLTAGE SHOCK, ALWAYS FOLLOW PRECISELY ALL WARNINGS AND SERVICE INSTRUCTIONS INCLUDING INSTRUCTIONS TO DEPOWER THE SYSTEM. THE TOTAL VOLTAGE OF THE VEHICLE HV BATTERY PACK MAY BE UP TO APPROXIMATELY 450 VOLTS DC. THIS VOLTAGE IS PROVIDED THROUGH HIGH-VOLTAGE CABLES TO ITS COMPONENTS AND MODULES. THE HIGH-VOLTAGE CABLES AND WIRING ARE IDENTIFIED BY ORANGE HARNESS TAPE OR ORANGE WIRE COVERING. ALL HIGH-VOLTAGE COMPONENTS ARE MARKED WITH HIGH-VOLTAGE WARNING LABELS WITH A HIGH-VOLTAGE SYMBOL. FAILURE TO FOLLOW THESE INSTRUCTIONS MAY RESULT IN SERIOUS PERSONAL INJURY OR DEATH.

 **WARNING:**

SERVICE OF THE HIGH VOLTAGE SYSTEM ON THIS VEHICLE IS RESTRICTED TO QUALIFIED PERSONNEL. THE REQUIRED QUALIFICATIONS VARY BY REGION. ALWAYS OBSERVE LOCAL LAWS AND LEGISLATIVE DIRECTIVES REGARDING ELECTRIC VEHICLE SERVICE. FAILURE TO FOLLOW THIS INSTRUCTION MAY RESULT IN SERIOUS PERSONAL INJURY OR DEATH.

 **WARNING:**

NEVER CONNECT THE SERVICE DISCONNECT WHEN A HIGH-VOLTAGE COVER IS REMOVED. ALWAYS INSTALL THE COVER PRIOR TO CONNECTING THE SERVICE DISCONNECT. THE COVER PREVENTS INADVERTENT CONTACT WITH THE HIGH VOLTAGE WHICH IS PRESENT AT SEVERAL POINTS UNDER THE COVER. FAILURE TO FOLLOW THESE INSTRUCTIONS MAY RESULT IN SERIOUS PERSONAL INJURY OR DEATH.

 **WARNING:**

DISCONNECT THE 12V BATTERY BEFORE SERVICING THE DIRECT CURRENT TO ALTERNATING CURRENT (DC-AC) INVERTER OR ALTERNATING CURRENT (AC) POWERPOINT TO PREVENT THE RISK OF HIGH VOLTAGE SHOCK. FAILURE TO FOLLOW THIS INSTRUCTION MAY RESULT IN SERIOUS PERSONAL INJURY.

NOTICE:

Do not backprobe, splice or repair the high voltage (orange) wiring. Voltage in the system is approximately 450 volts DC. Damage may occur to equipment added to the system.

NOTICE:

None of the High Voltage Traction Battery (HVTB) wiring should be tapped or spliced to check for battery voltage (power), ground or signals.

Battery Removal Guide

NOTICE:

Modification of Low-Voltage (LV) power & control wires connecting to the High-Voltage (HV) battery system can damage or disable the HV Battery system. Do not open or modify High Voltage battery pack

High Voltage Battery Depowering using FDRS

**WARNING:**

Before beginning any service procedure in this manual, refer to health and safety warnings in Workshop Manual (WSM) Section 100-00 General Information. Failure to follow this instruction may result in serious personal injury.

**WARNING:**

To prevent the risk of high-voltage shock, always follow precisely all warnings and service instructions, including instructions to depower the system. The high-voltage system utilizes approximately 450 volts DC, provided through high-voltage cables to its components and modules. The high-voltage cables and wiring are identified by orange harness tape or orange wire covering. All high-voltage components are marked with high-voltage warning labels with a high-voltage symbol. Failure to follow these instructions may result in serious personal injury or death.

1. Using the FDRS CARRY OUT the Zero Voltage Confirmation routine and follow the on-screen instructions.
2. Detach the pin-type retainer and position the electrical connector and wiring harness aside.

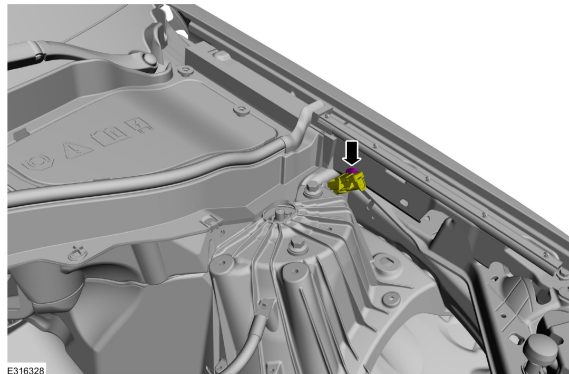

3. Release the Connector Position Assurance (CPA) clip.

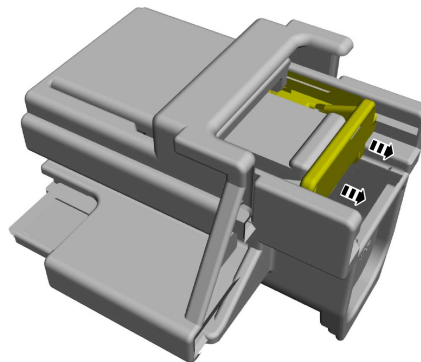
**NOTE:**

The tab must be depressed prior to pushing the connector back in or damage to the connector may result.

Depress the tab while pulling the connector until the hole is completely visible on the top of the connector.

Battery Removal Guide

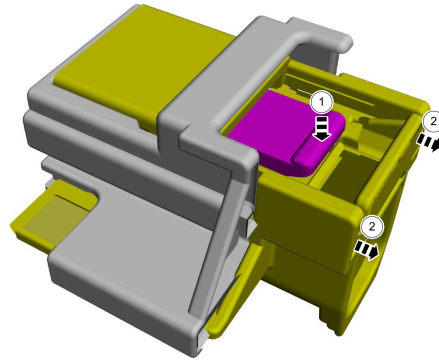

E316330

5. Insert a suitable tool inside the connector hole to prevent the connector from closing.

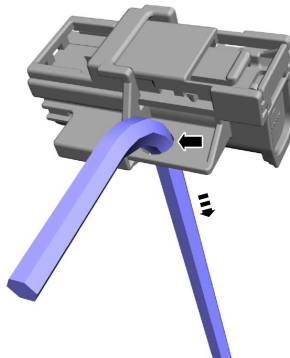

E316331

6. Using the FDRS COMPLETE the Zero Voltage Confirmation routine and verify the High Voltage System has been de-energized.

Manual De-Energizing

WARNING:

To prevent the risk of high-voltage shock, always follow precisely all warnings and service instructions, including instructions to depower the system. The high-voltage system utilizes approximately 450 volts DC, provided through high-voltage cables to its components and modules. The high-voltage cables and wiring are identified by orange harness tape or orange wire covering. All high-voltage components are marked with high-voltage warning labels with a high-voltage symbol. Failure to follow these instructions may result in serious personal injury or death.

WARNING:

Before beginning any service procedure in this manual, refer to health and safety warnings in WSM Section 100-00 General Information. Failure to follow this instruction may result in serious personal injury.

NOTICE:

Manual De-energization should only be performed when a Ford-specific diagnostic tool is not available.

NOTICE:

Excessive use of this method may cause damage to electrical connectors.

NOTICE:

To prevent the risk of high voltage shock, the high voltage battery cover must not be removed if any of the following condition exist:

- BECM DTC P0AA6:00 that has been diagnosed to be an internal fault with the high voltage Battery.
- BECM Diagnostic Trouble Codes (DTCs) P0AA1:00 AND P0AA4:00 are present.

Battery Removal Guide

- **BECM Diagnostic Trouble Codes (DTCs) P0D0F:00 AND P0AA4:00 are present (PHEV only).**
1. Disconnect the Electric Vehicle Supply Equipment (EVSE) from the vehicle charge port. (PHEV only).
 2. Turn the ignition ON without depressing the brake pedal (Accessory mode).
 3. **NOTE:**
A scan tool that is capable of performing a self-test on the BECM is required.

Using a scan tool perform BECM self test and record the Diagnostic Trouble Codes (DTCs).

- If BECM Diagnostic Trouble Codes (DTCs) P0AA1:00 AND P0AA4:00 are present. Refer to WSM procedures in section 414-03 High Voltage Battery, Mounting and Cables, Diagnosis and Testing.

- If BECM Diagnostic Trouble Codes (DTCs) P0D0F:00 AND P0AA4:00 are present (PHEV only). Refer to WSM Procedures in section 414-03A High Voltage Battery, Mounting and Cables - Plug-In Hybrid Electric Vehicle (PHEV).

4. Turn the ignition OFF.
5. Detach the pin-type retainer and position the electrical connector and wiring harness aside.

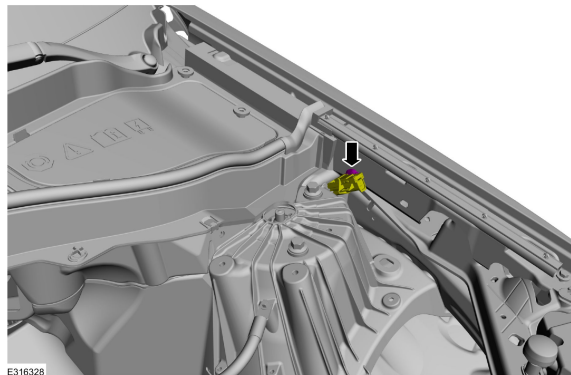

6. Release the Connector Position Assurance (CPA) clip.

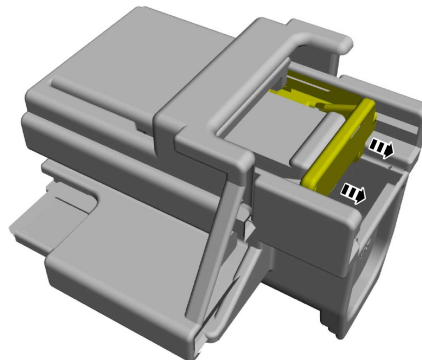

7. **NOTE:**
The tab must be depressed prior to pushing the connector back in or damage to the connector may result.
Depress the tab while pulling the connector until the hole is completely visible on the top of the connector.

Battery Removal Guide

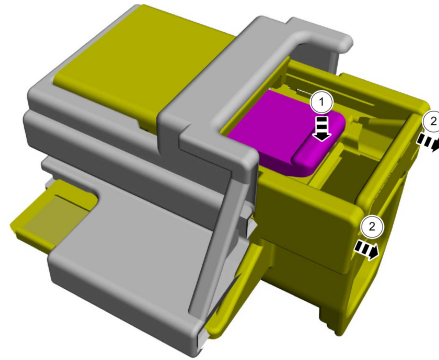

E316330

8. Insert a suitable tool inside the connector hole to prevent the connector from closing.

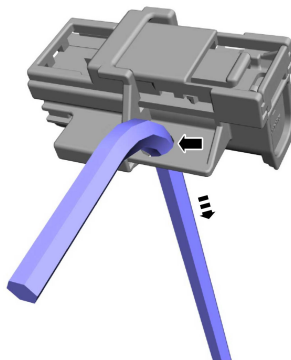

E316331

9. Disconnect the low voltage electrical connector at the High Voltage Battery.
10. Disconnect the high voltage electrical connector at the High Voltage Battery.
11. Wait a minimum of 5 minutes.

HEV — Battery Removal

NOTE:

Before proceeding ensure the high voltage service disconnect procedure has been preformed.

1. Remove the retainers on the right hand side aero deflector shield.

Battery Removal Guide

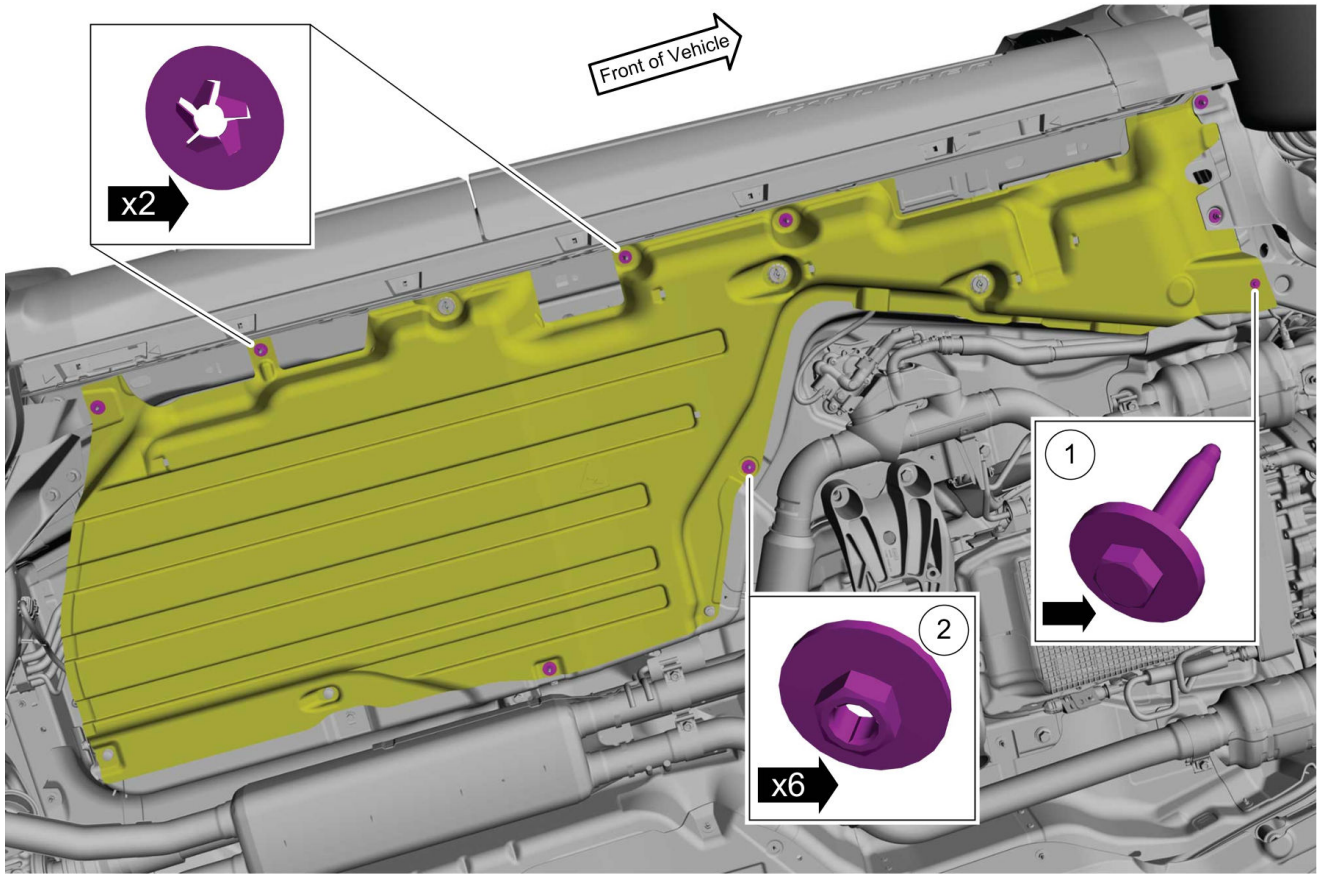

N0180483

2. Remove the retainers and the right hand side area deflector shield.

Battery Removal Guide

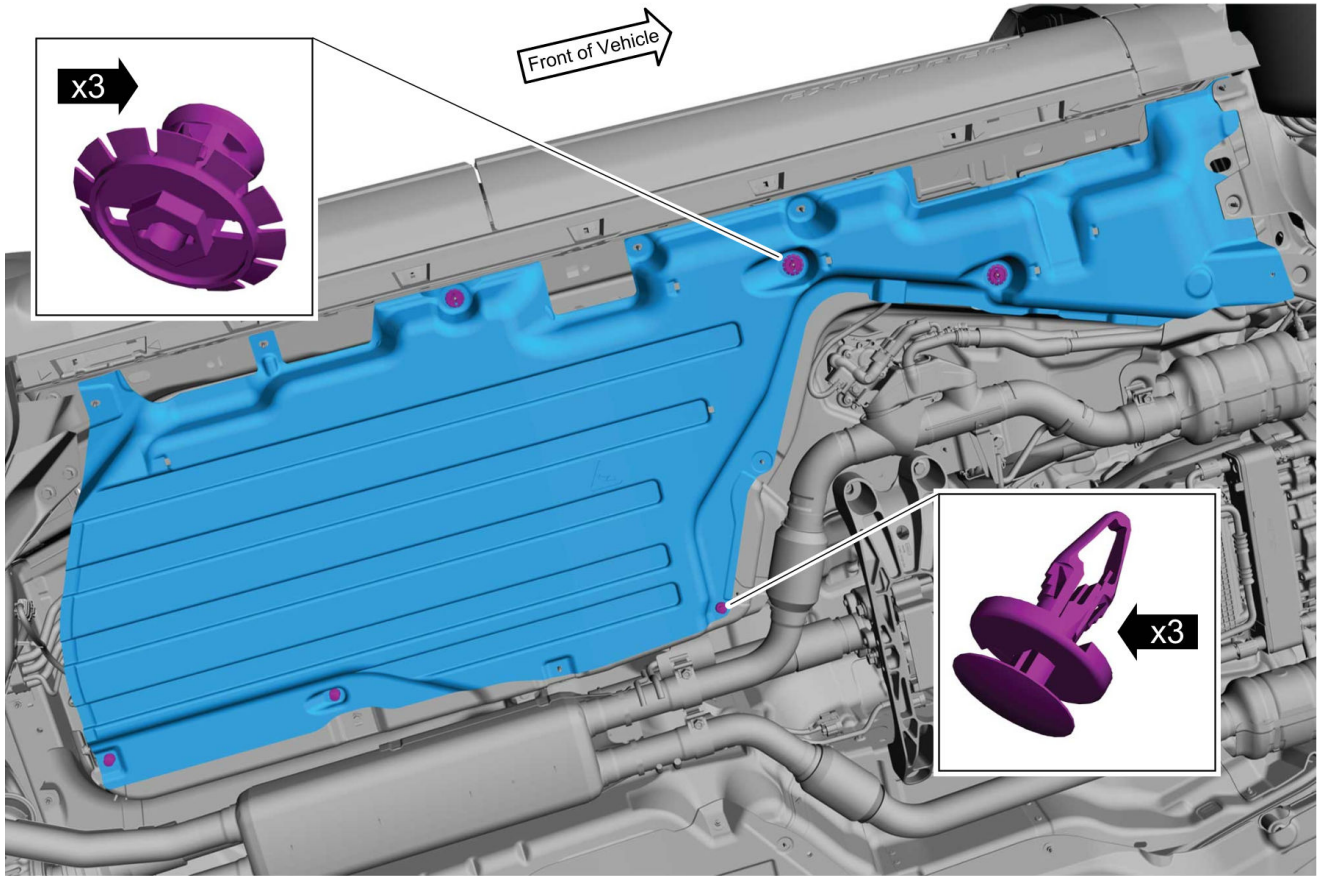

N0180484

3. Remove the retainers and position aside the heat shield.

Battery Removal Guide

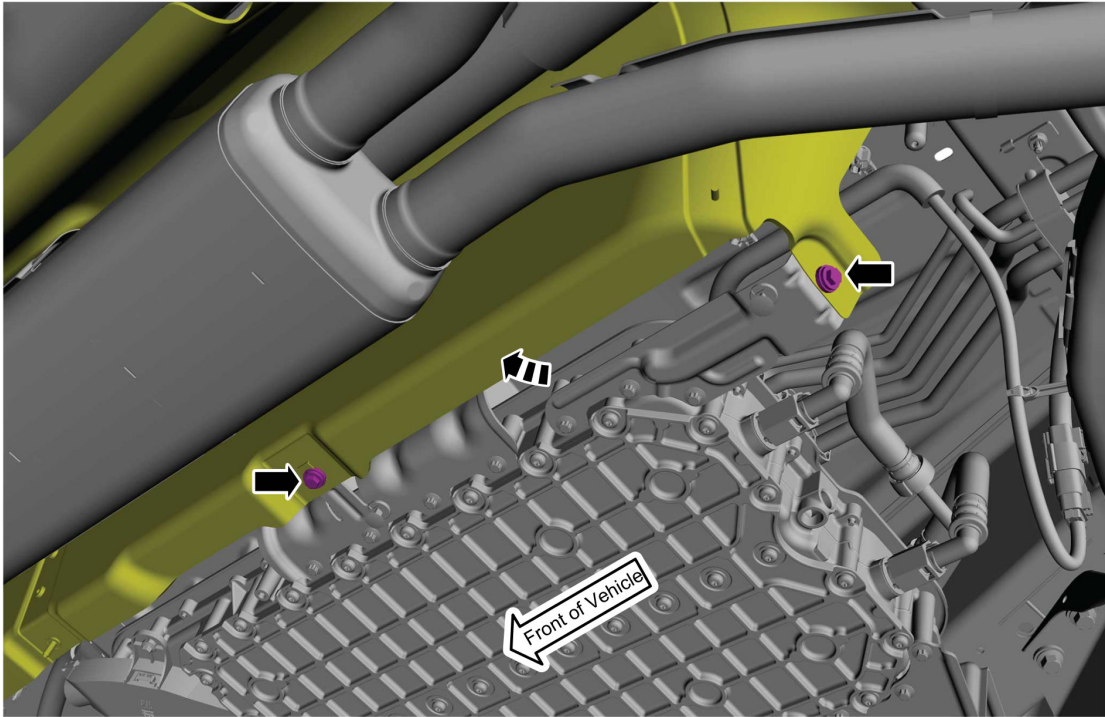

N0180537

- 4. Clamp the coolant hoses using hose clamp pliers and disconnect.

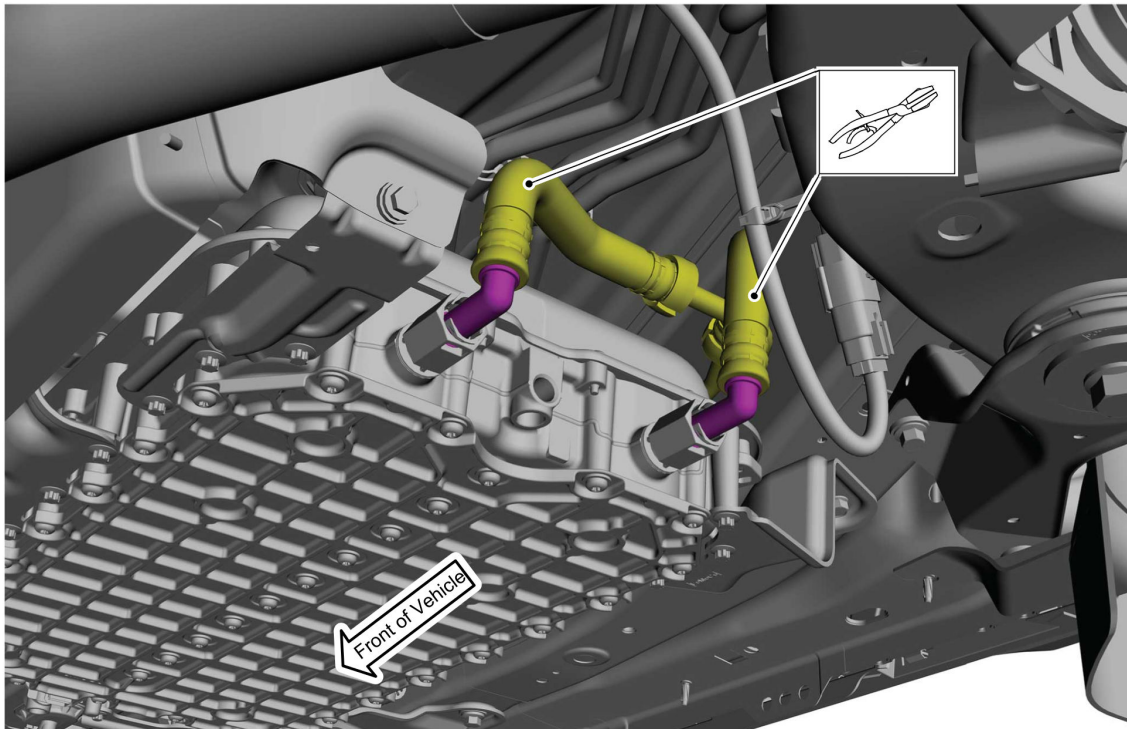

N0180538

- 5. Remove the retainers and position aside the wire shield.

Battery Removal Guide

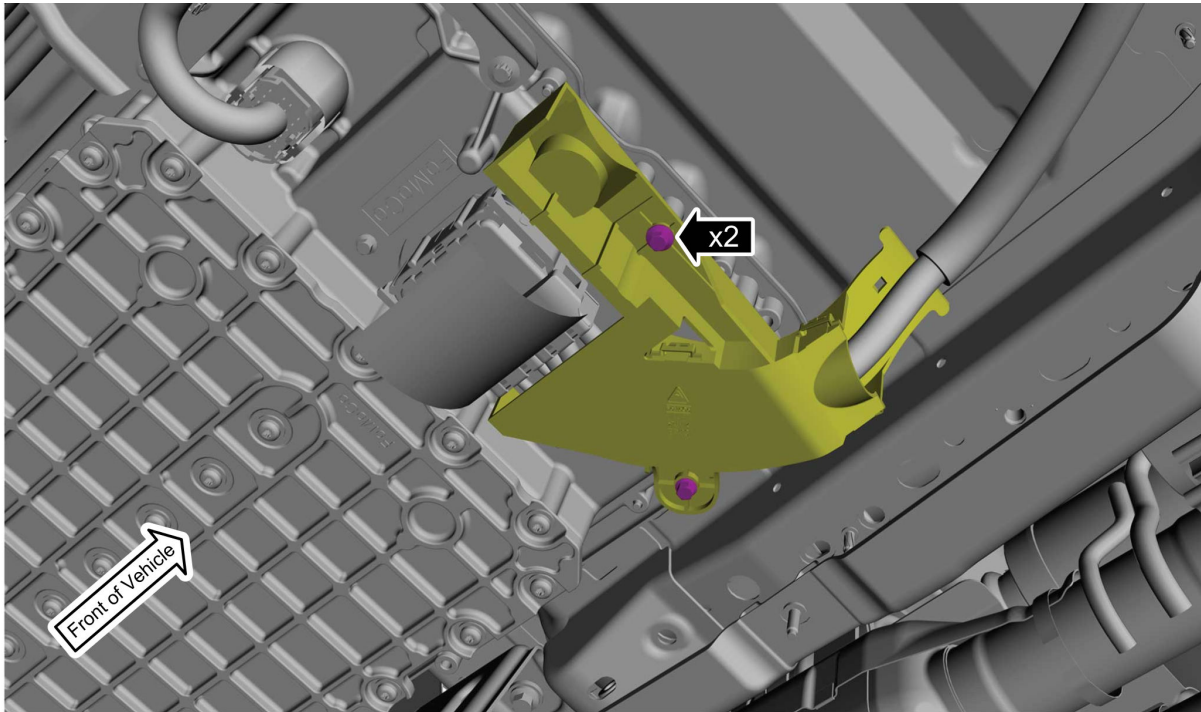

N0180496

6. Disconnect the electrical connector.

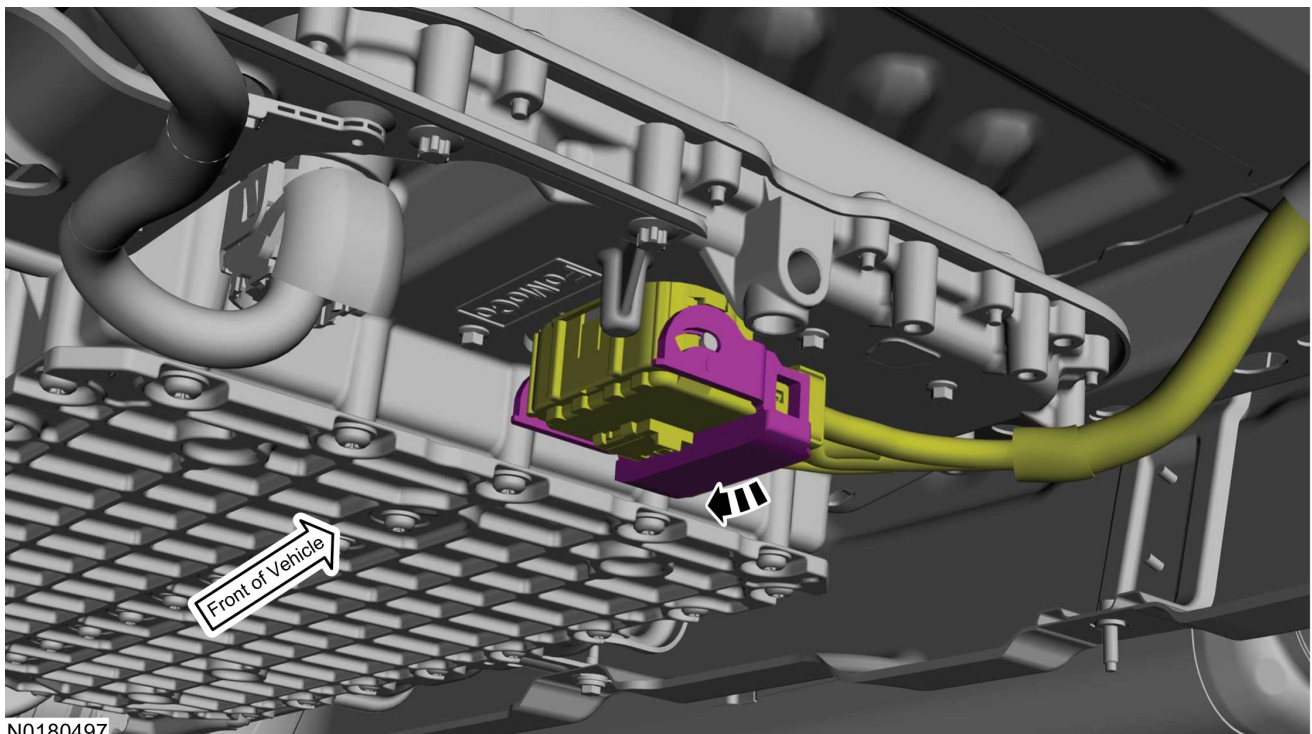

N0180497

7. Disconnect the electrical connector and wire retainer and position aside.

Battery Removal Guide

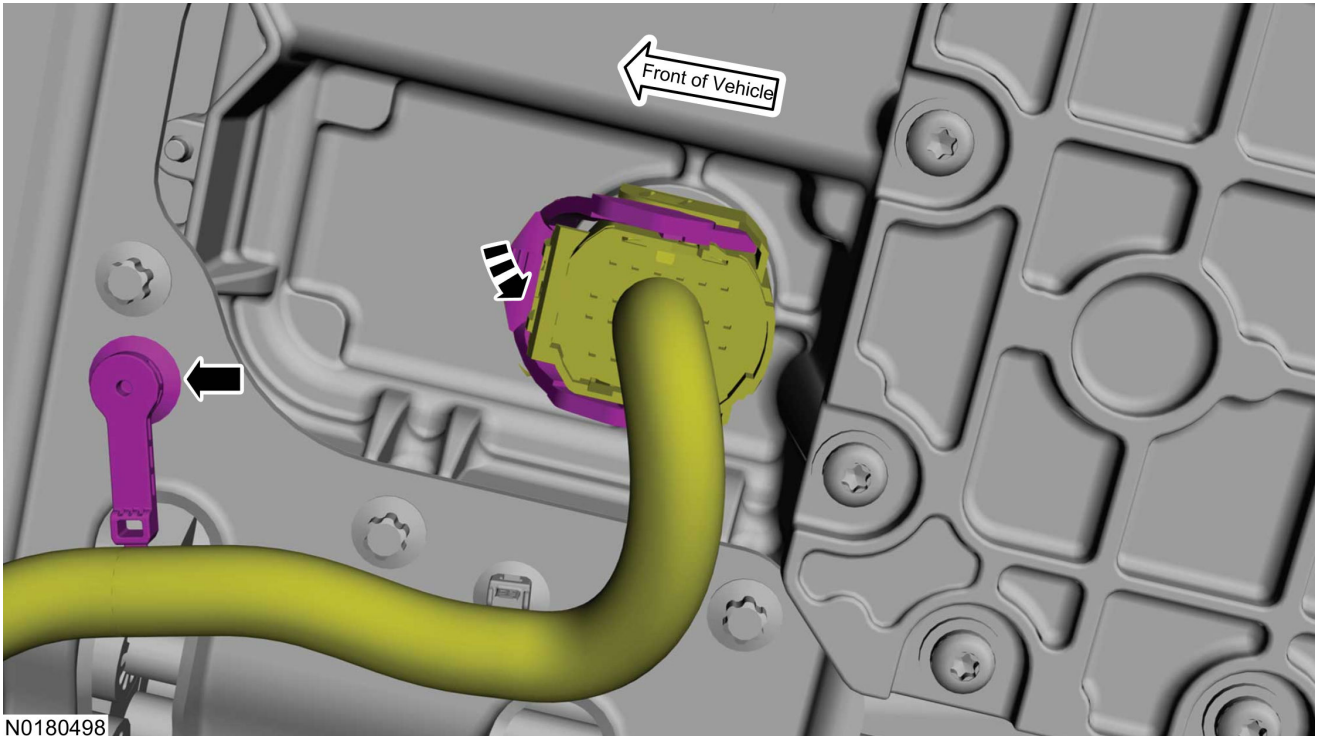

8. Position a powertrain jack and support the high voltage battery assembly.

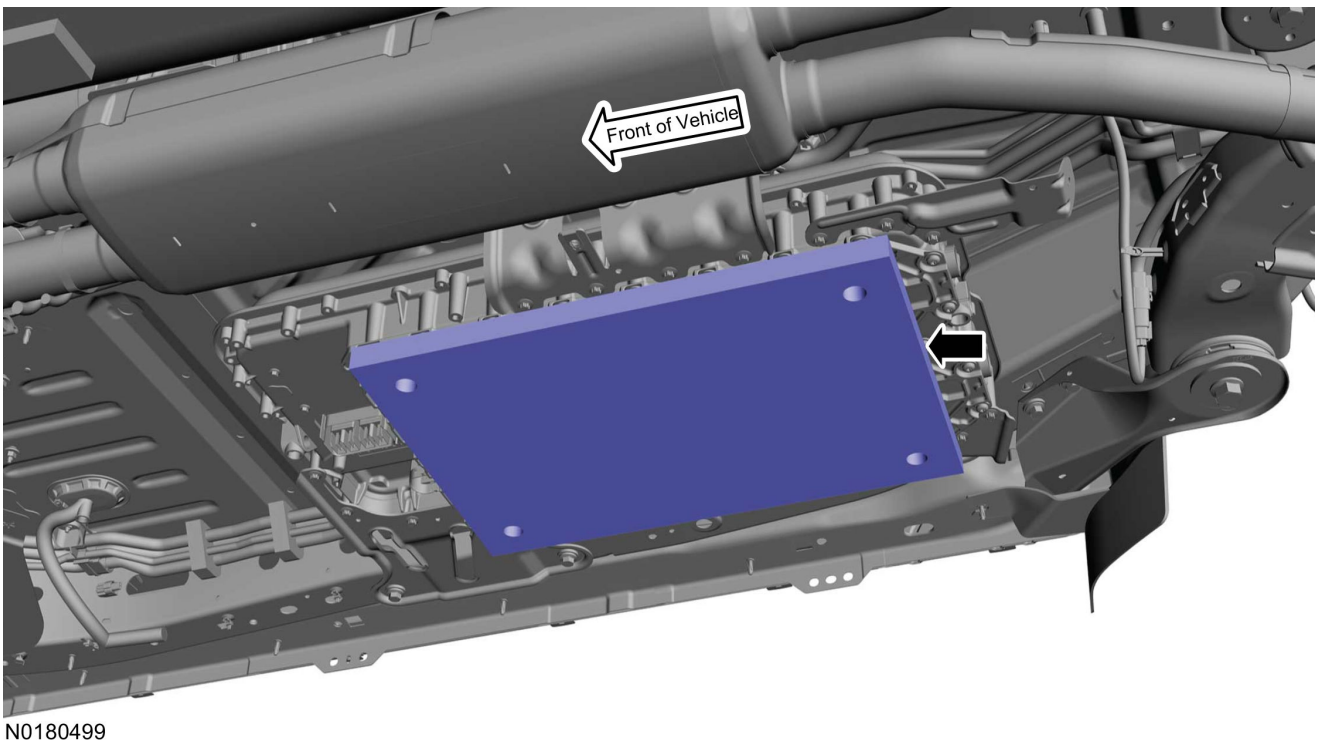

NOTE:
Use caution while removing the HV battery it has significant weight.

Battery Removal Guide

9. Remove the bolts and with the aid of an assistant along with the powertrain jack, lower the high voltage battery assembly.

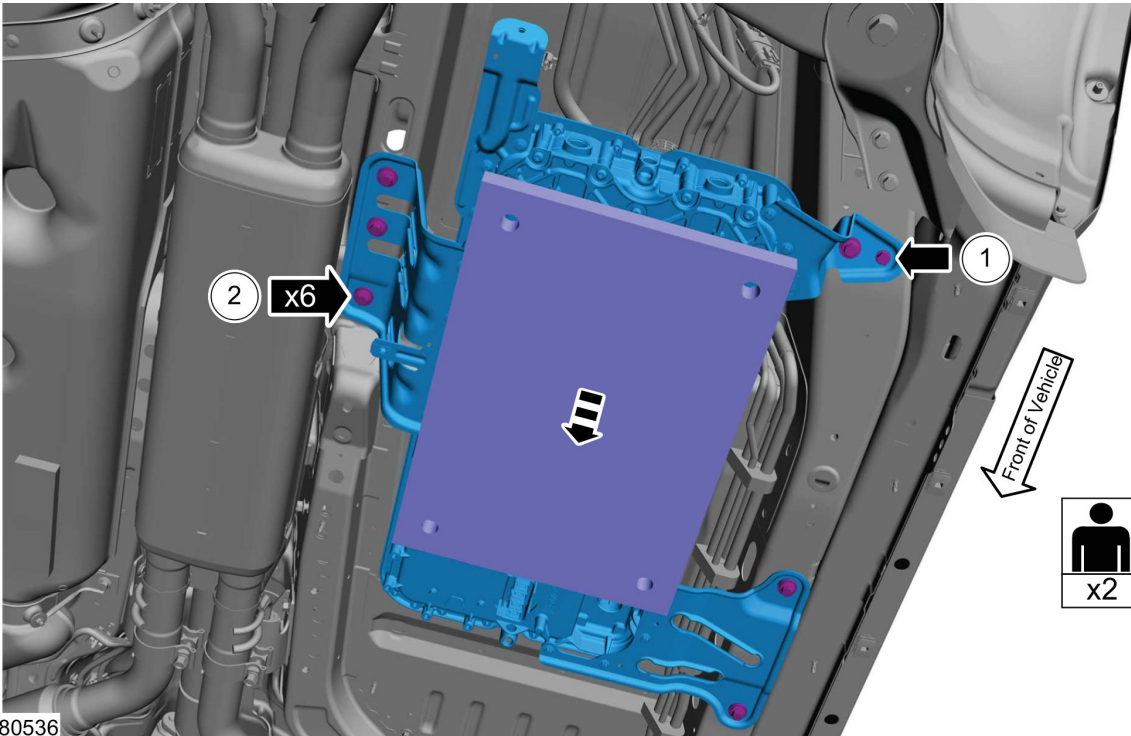

PHEV — Battery Removal

NOTE:

Before proceeding ensure the high voltage service disconnect procedure has been performed.

1. Remove the shield retainers

Battery Removal Guide

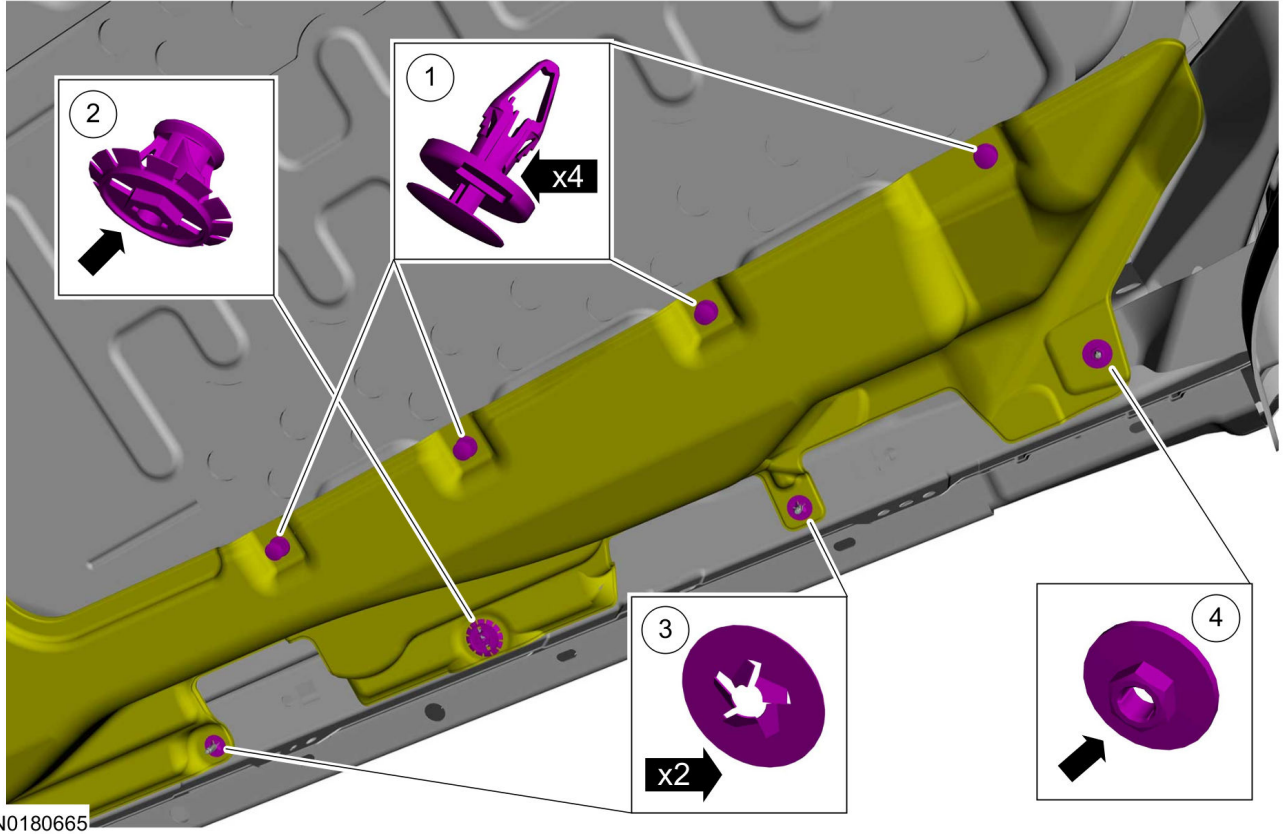

2. Remove the shield retainers.

Battery Removal Guide

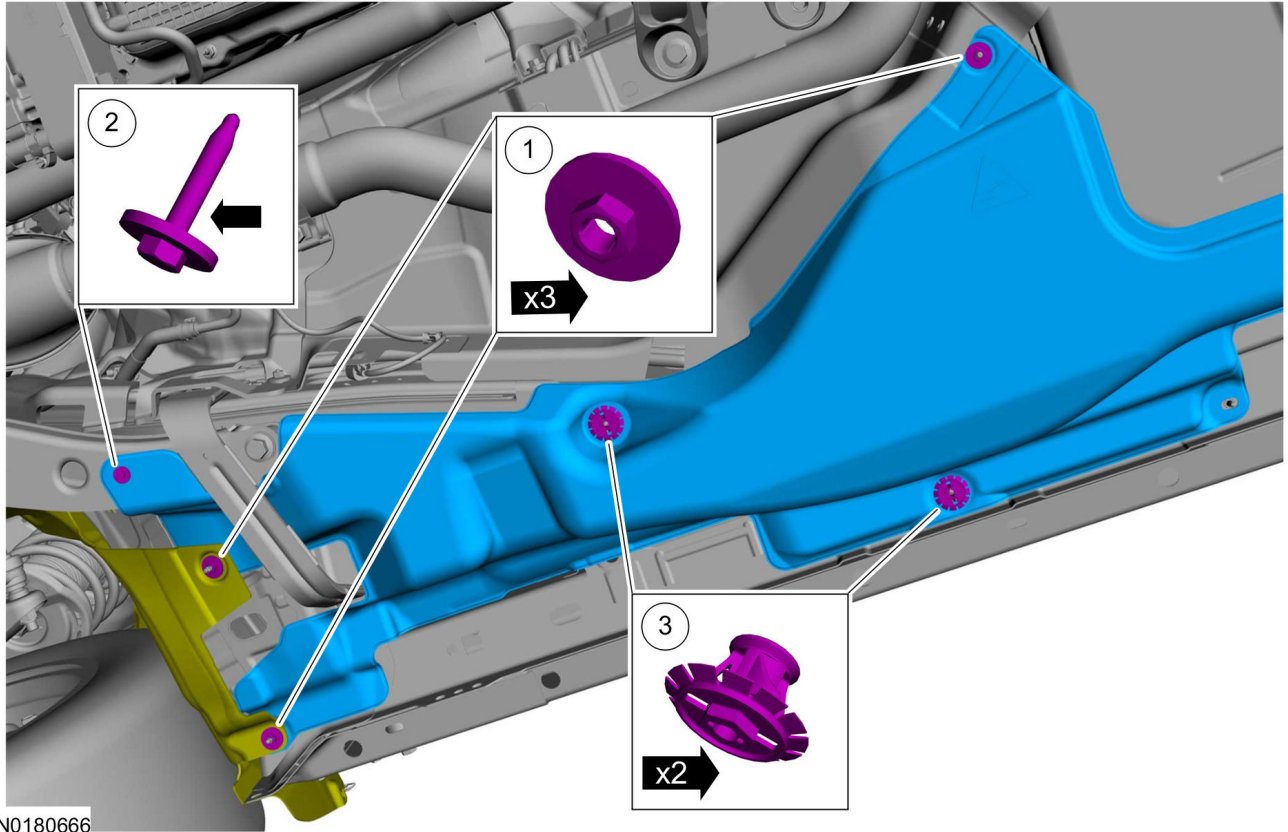

N0180666

3. Remove the shield retainers.

Battery Removal Guide

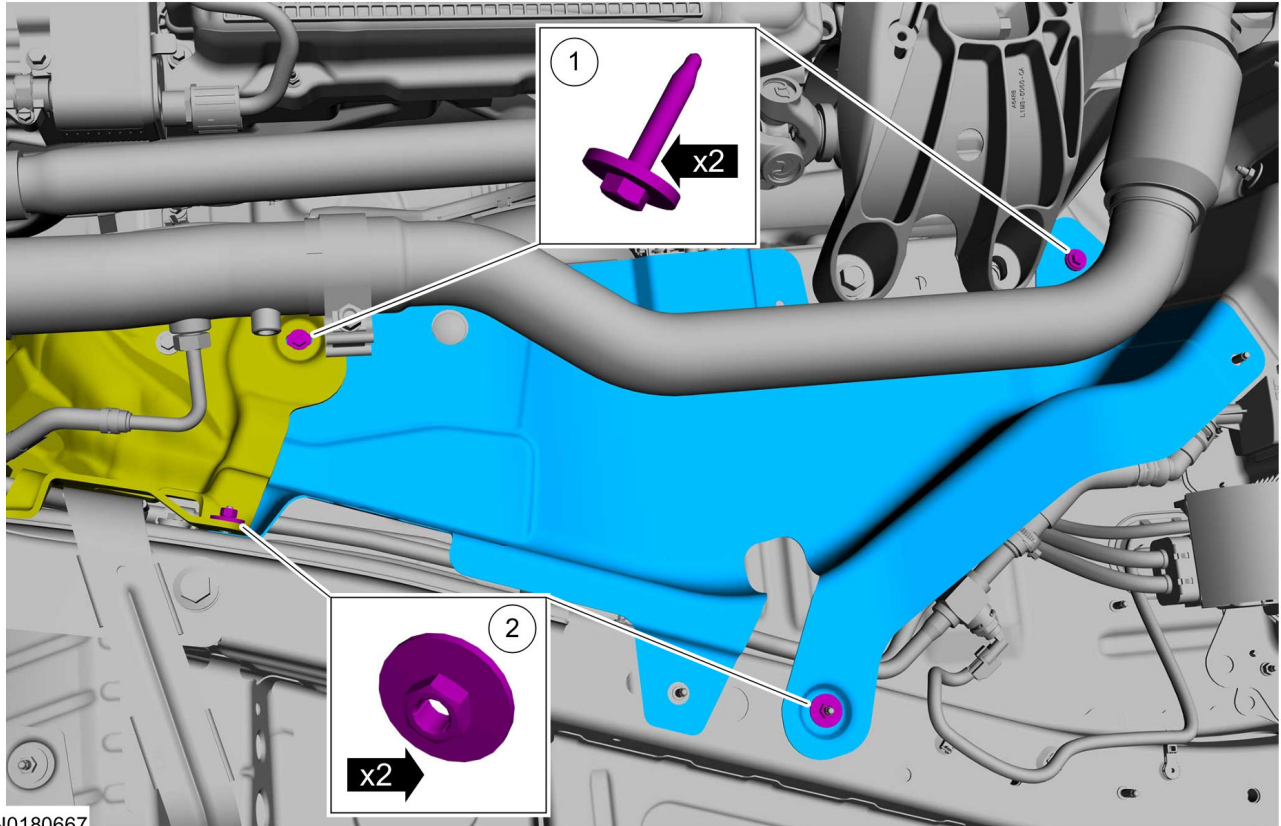

N0180667

- 4. Remove the bolts and the hanger brackets.

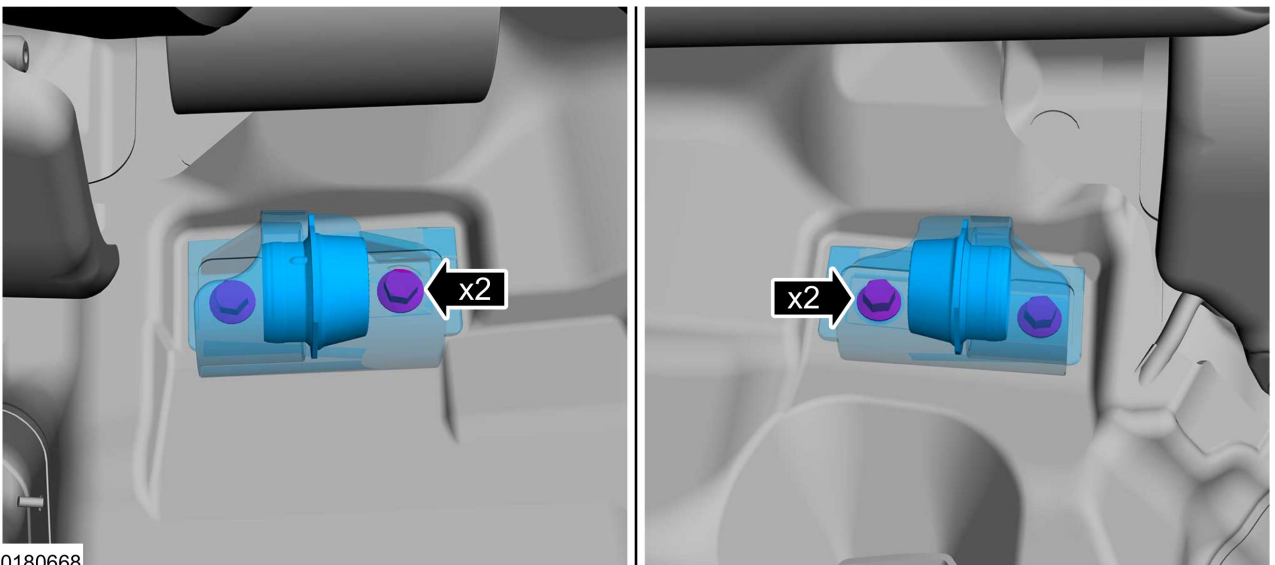

N0180668

- 5. Remove the muffler and tailpipe assembly and then rear driveshaft. Refer to workshop manual for removal procedures.
- 6. Remove the fasteners and position aside the heat shield.

Battery Removal Guide

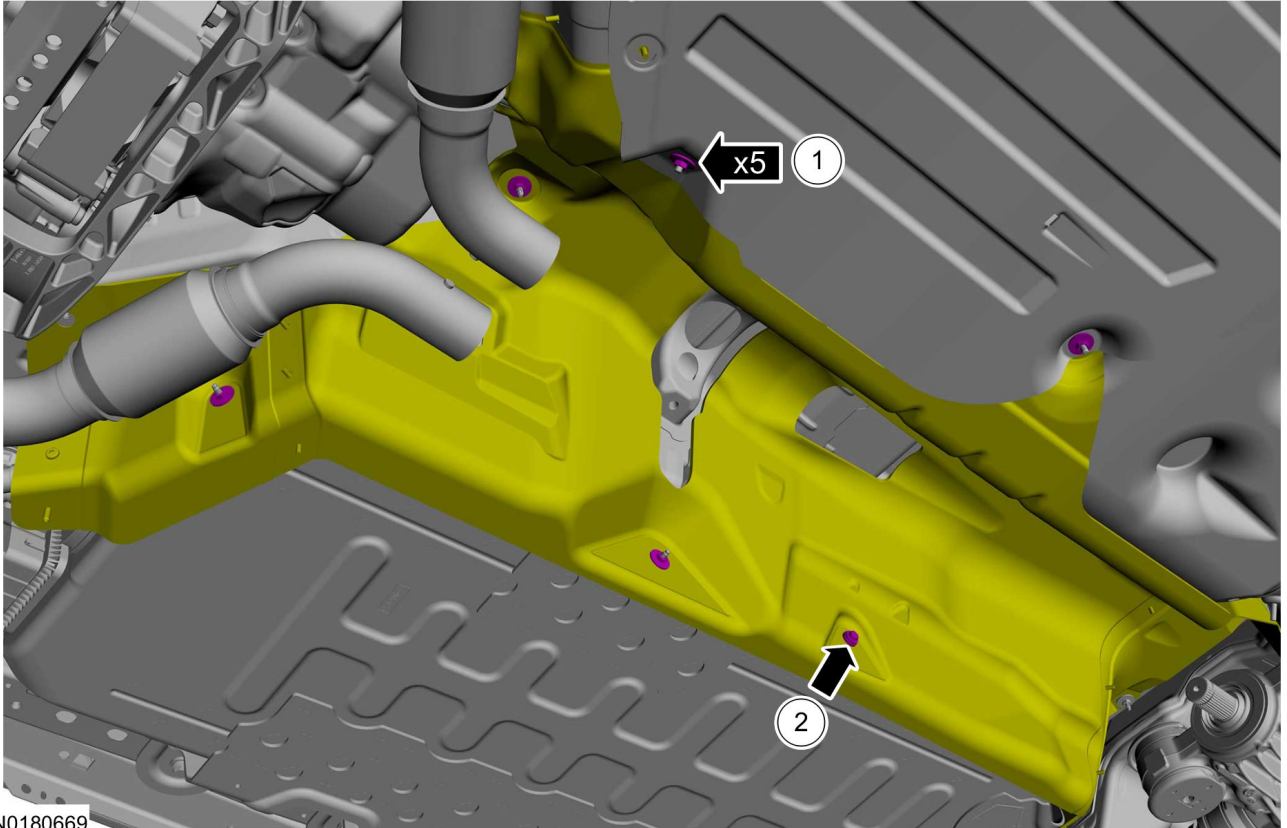

N0180669

7. Remove the fasteners and position aside the heat shield.

Battery Removal Guide

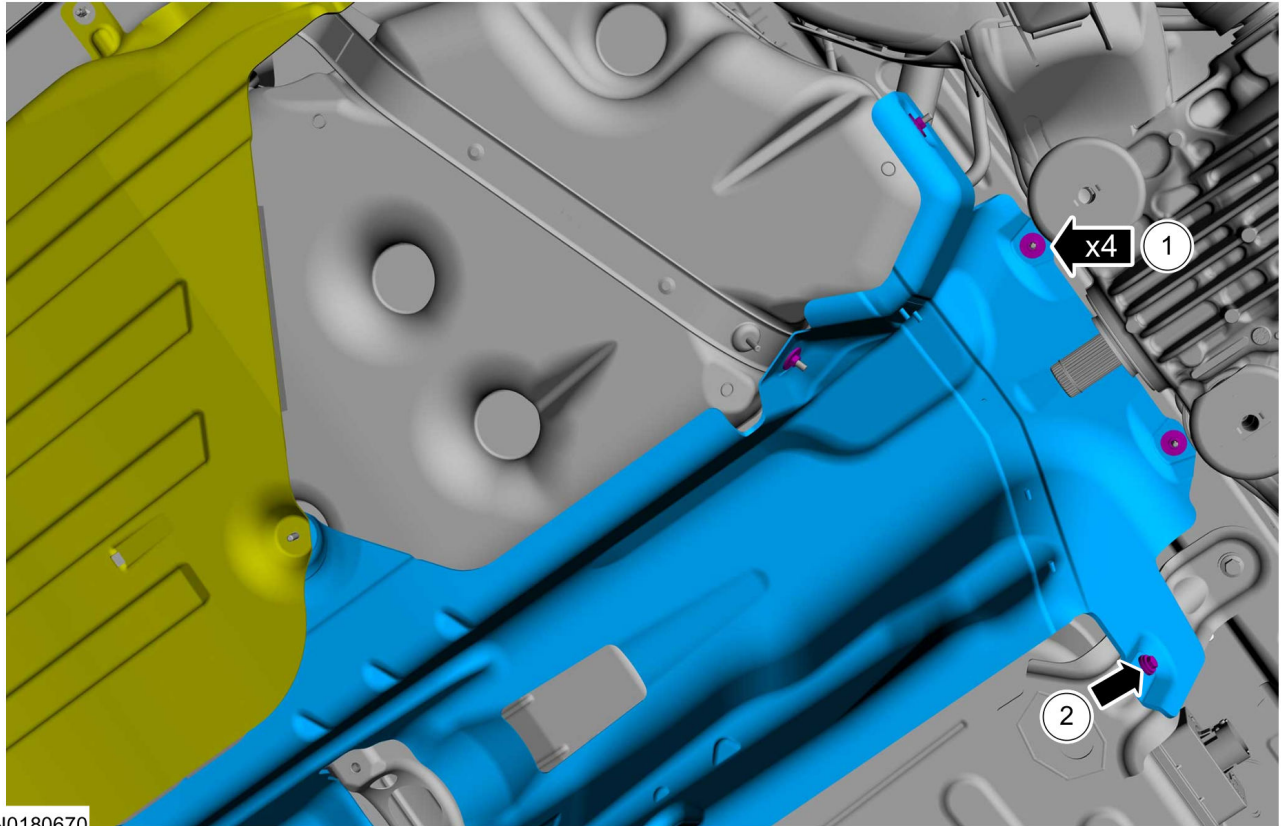

N0180670

8. Disconnect the electrical connector.

Battery Removal Guide

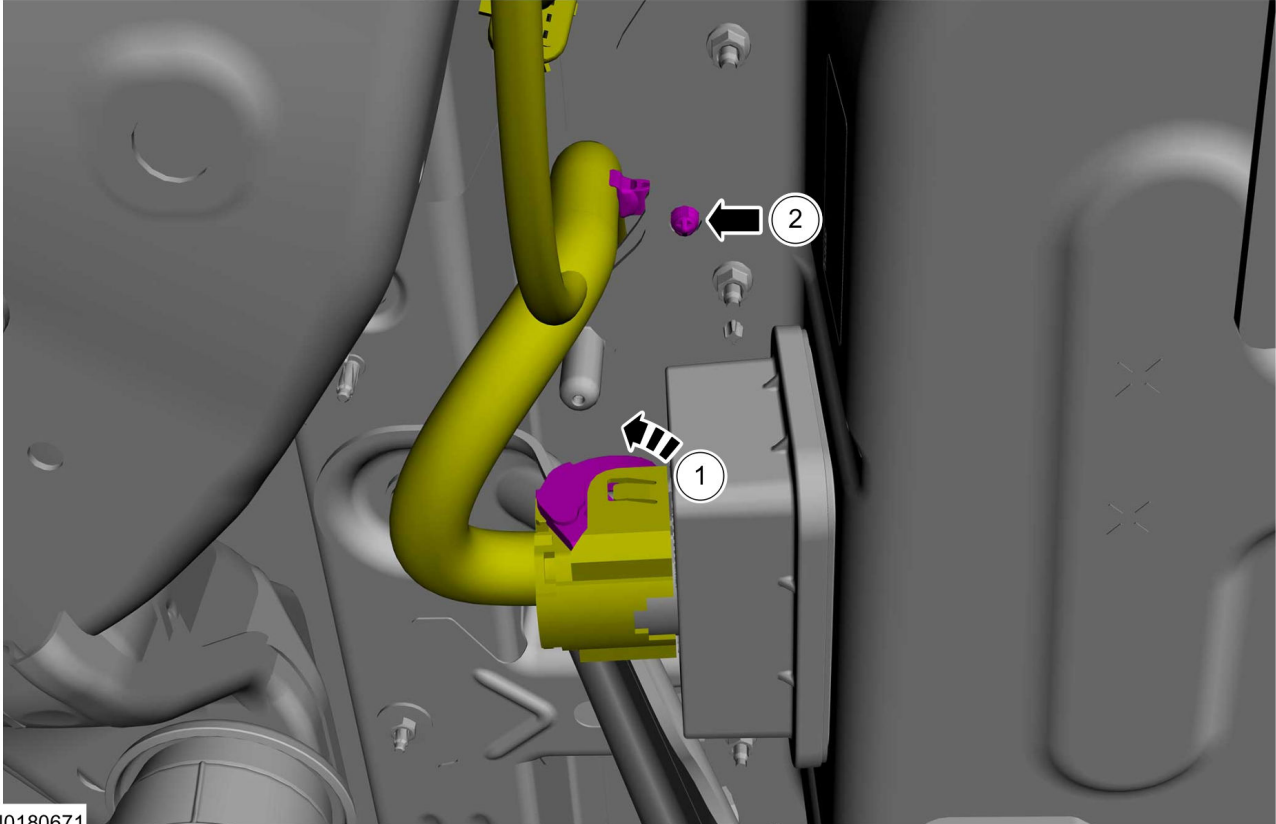

N0180671

9. Disconnect the electrical connector.

Battery Removal Guide

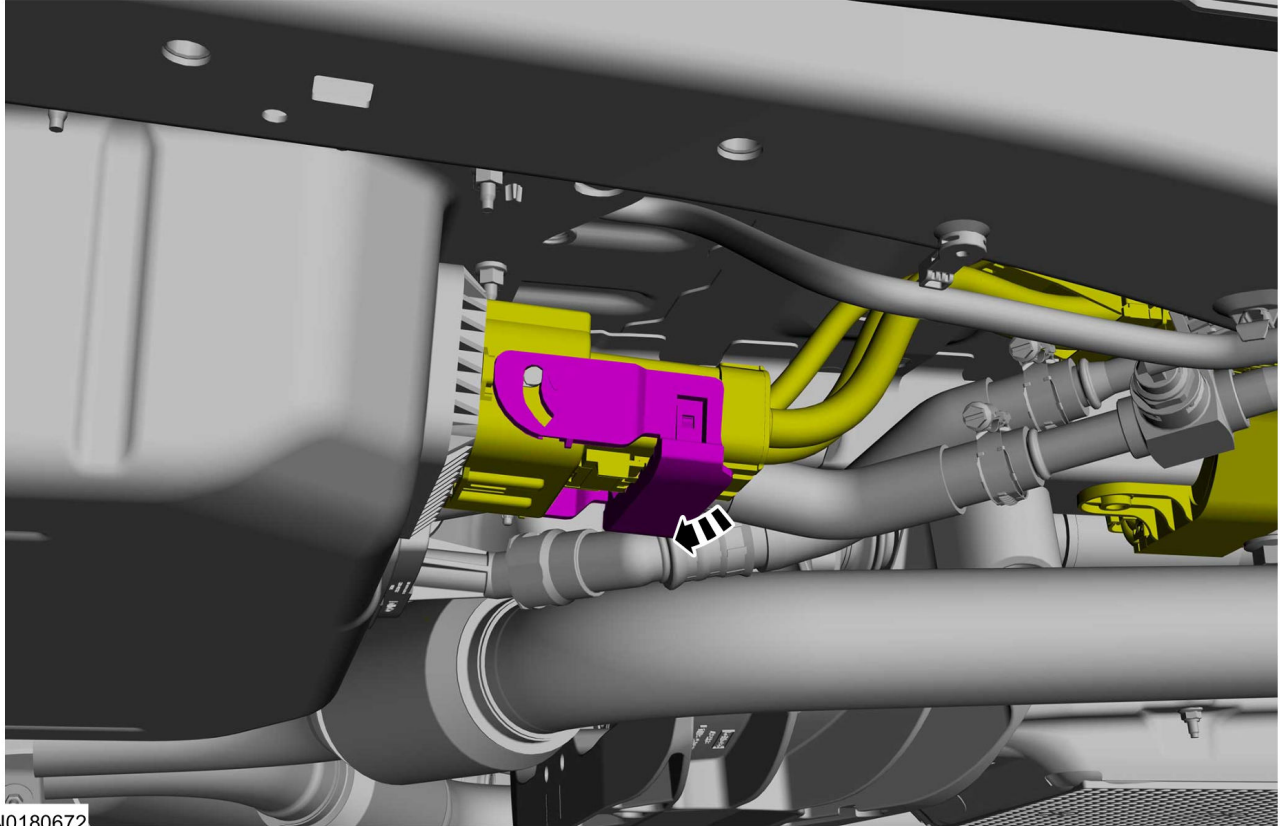

N0180672

10. Remove the coolant hoses.

Battery Removal Guide

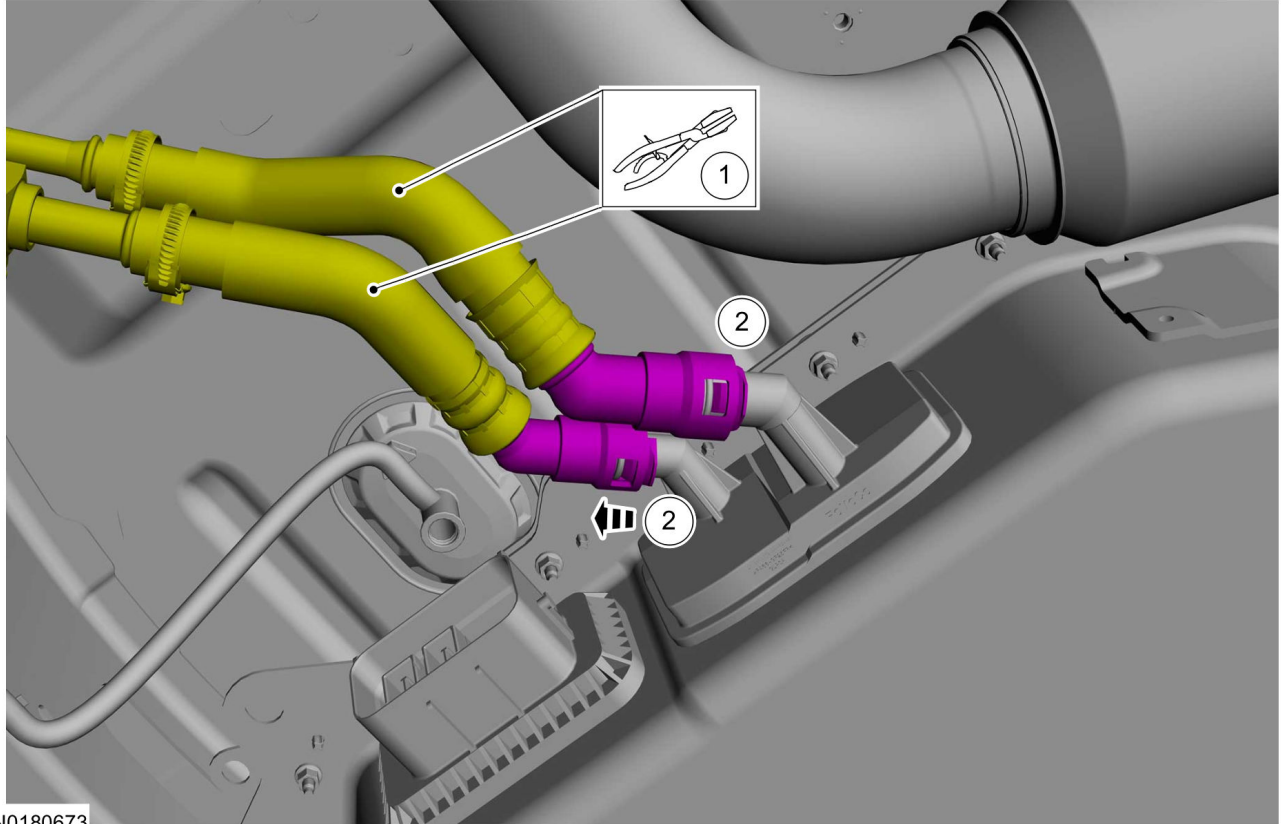

N0180673

11. Install the shipping caps.

Battery Removal Guide

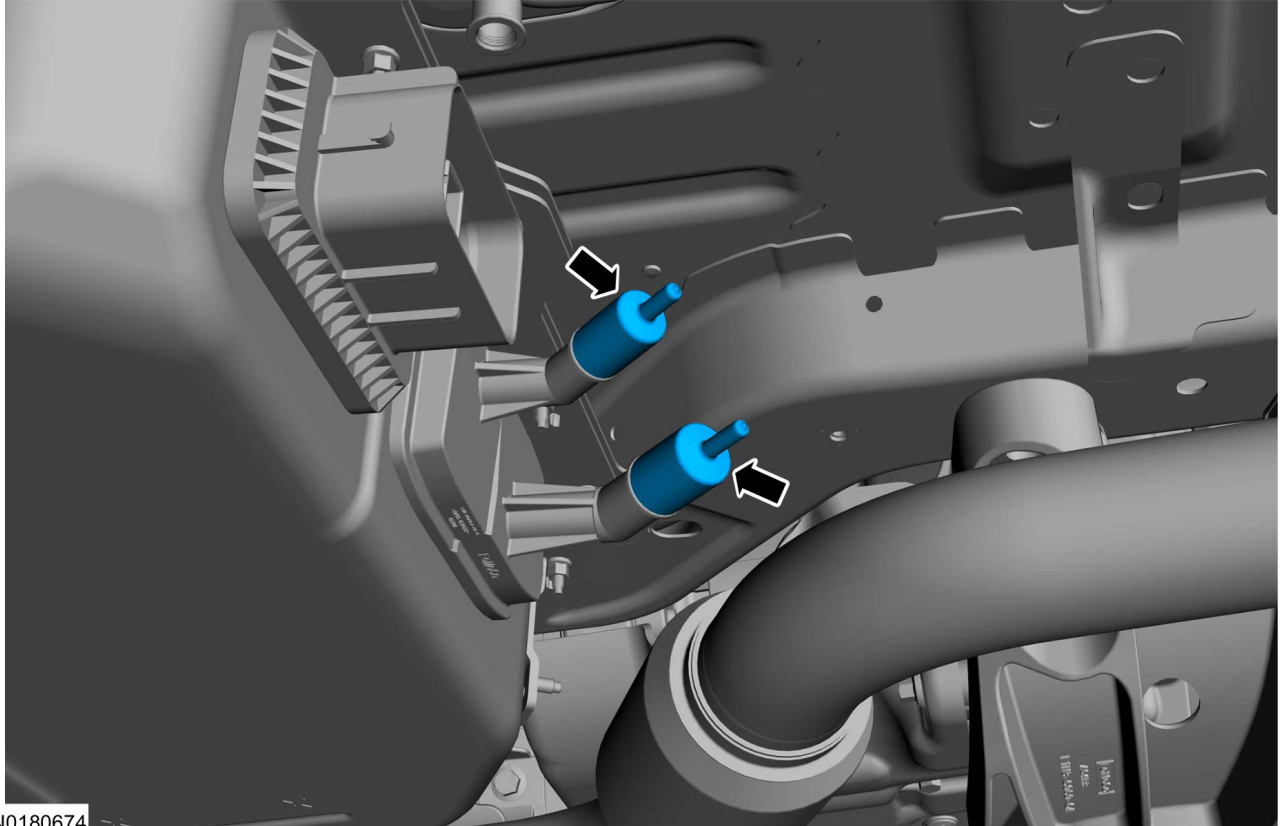

12. Position the powertrain jack and support the high voltage battery assembly.

Battery Removal Guide

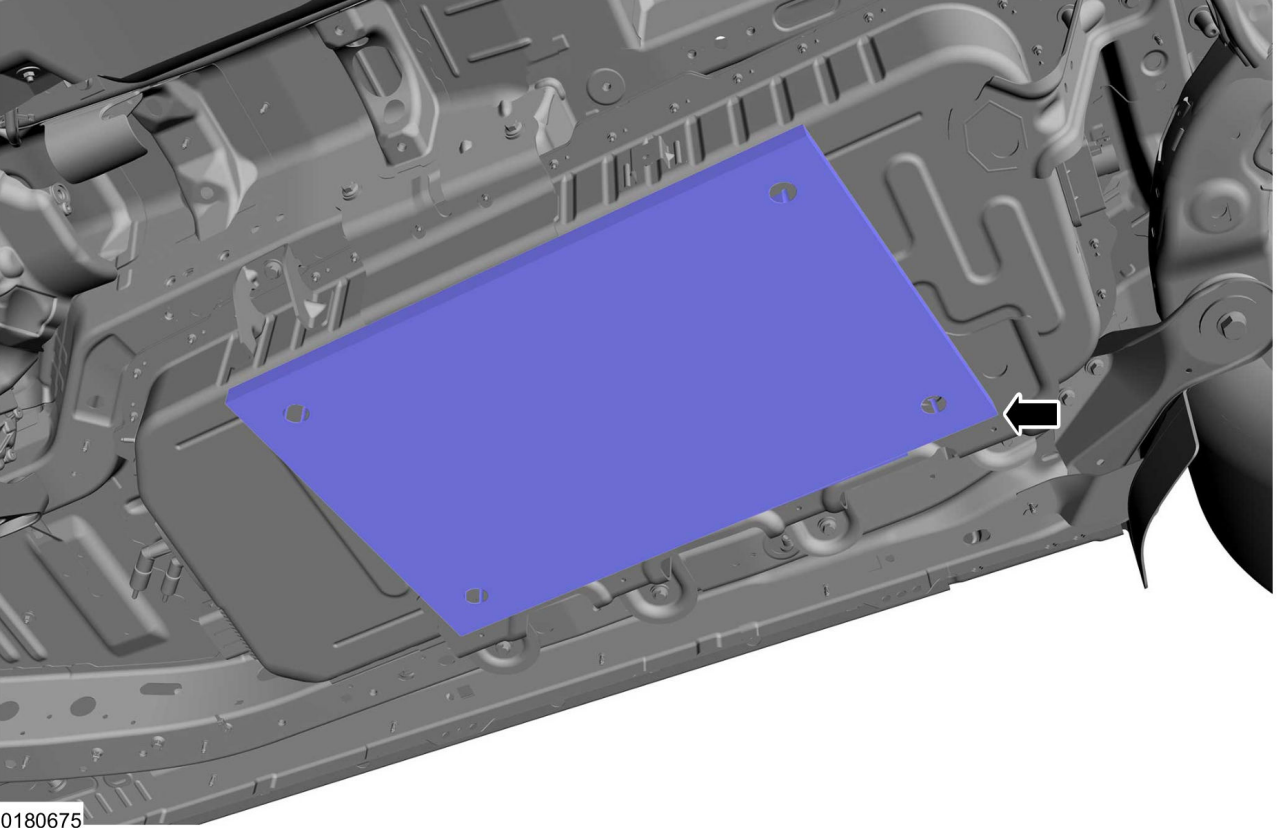

N0180675

NOTE:

Use caution while removing the HV battery it has significant weight.

13. With the aid of an assistant and using the powertrain jack, remove the bolts and lower/remove the high voltage battery assembly

Battery Removal Guide

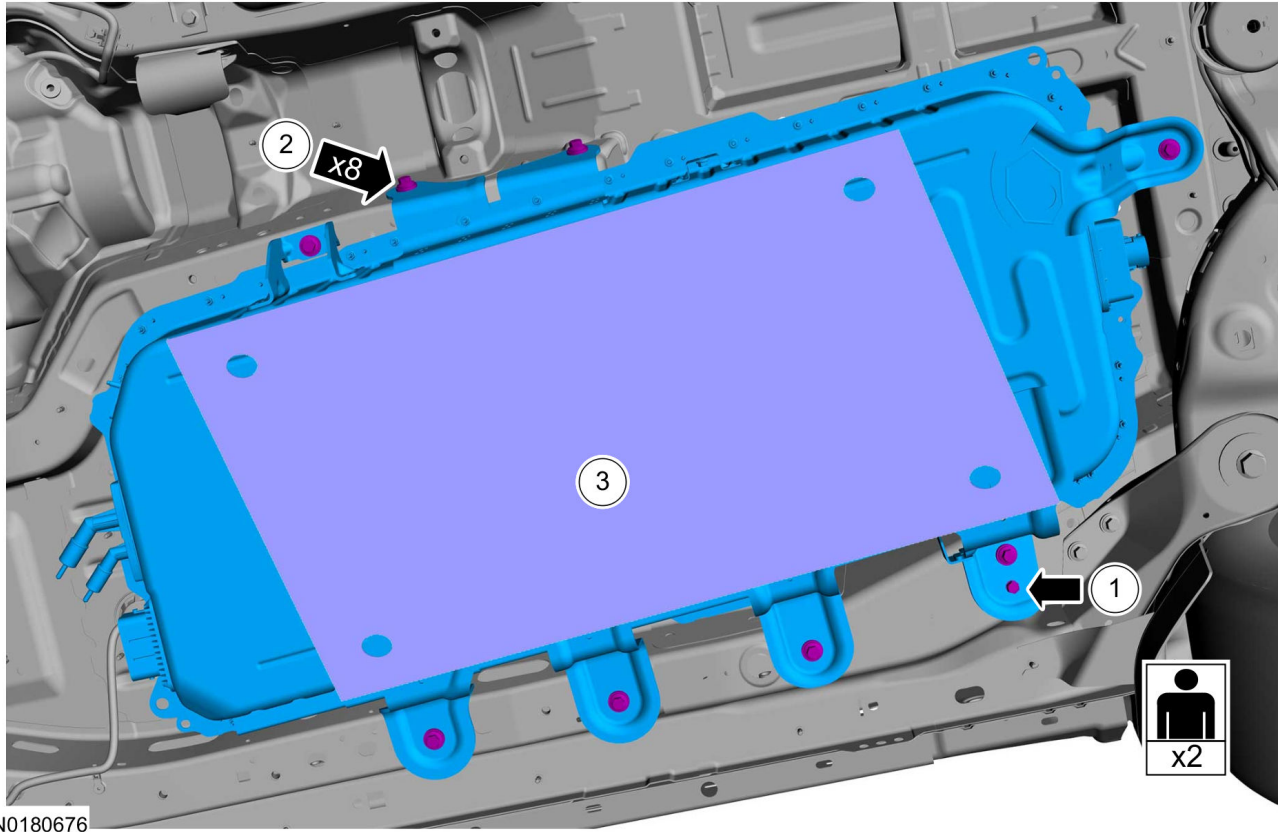

N0180676

SPECIAL NOTE TO DISMANTLERS AND SALVAGE YARDS

If a vehicle with a high voltage battery is to be scrapped, the high voltage battery must be disposed of following all local, state/provincial and federal guidelines.

The vehicle's Lithium-Ion High Voltage Battery pack (Li-Ion HVB) is fully recyclable and should be shipped to a permitted recycling facility. The guidelines below are for Li-Ion HVBs which have been removed from the vehicle and discharged.

General Packaging, Transport, and Recycling Guidelines

Once the battery has been removed from the vehicle and discharged:

- Store the battery components in a building or under shelter so that batteries are kept dry and not exposed to high temperatures.
- Protect battery components from damage (e.g. crushed or punctured).
- It is recommended to ask about the specific packaging requirements for battery shipments to the recycler who will be receiving the battery components in order to avoid inappropriate repacking/stacking of the batteries.
- Batteries should be sorted by type. Keep lead acid batteries, NiMH batteries, and Li-Ion batteries separated from each other (e.g. separate pallets or storage locations).
- Make sure the battery recycler is aware of the battery type. Li-ion batteries cannot be recycled in the same manner as lead acid or NiMH batteries.

Though Ford Motor Company makes no representations or endorsements, there are companies that have the capability to accept, consolidate and recycle undamaged Li-Ion HVBs, and a few are listed below. Contact the appropriate battery manufacturer for additional information.

North America Battery Recyclers

Once the battery has been removed from the vehicle and discharged:

Kinsbury Brothers, Inc. 125 E Commercial St suite a, Anaheim, CA 92801: Phone: (714) 738-8516

Retriev Technologies, Inc. 265 Quarry Rd SE Lancaster, OH 43130: Phone: (740) 653-6290

Battery Removal Guide

Applicable Laws/Regulations

The following is a general explanation of certain applicable laws; however, these laws change from time to time, additional regulations are under development and Ford Motor Company makes no representation that this is a complete summary.

Packaging and Transport

Packaging and Transport The U.S. Department of Transportation (DOT) outlines packaging and shipping requirements for Li-Ion batteries. Certain exceptions on packaging and transportation regulations for large format Li-Ion batteries may be found in 49CFR 173.185 (d) and (f). Make sure that the shipping paperwork is filled out correctly and that the shipment is properly labeled per federal, state, and local laws and regulations. Ensure that you are complying with any record keeping requirements. Generally, under U.S. DOT regulations, Li-Ion batteries are considered a dangerous good and regulated as hazardous materials when transported. Li-Ion batteries are classified as Class 9 hazardous material. Only certified hazardous material shippers should offer transport of a hazardous material. Batteries for recycling should be shipped by ground or vessel only. Do not ship batteries for recycling by air.

NOTE:

A damaged battery (one that is leaking electrolyte from the battery pack) might need to be shipped as a hazardous waste. If you are transporting a damaged battery, utilize a company that specializes in hazardous waste transport and management. Ensure that you comply with all applicable hazardous waste management laws and regulations.

Recycling

40 CFR 261 states that manufactured articles that yield extracts which exceed one or more of the concentration limits of regulated listed constituents, or meets the definition of ignitability, corrosivity or reactivity are defined as hazardous wastes and must be disposed of in accordance with federal and state regulations. Since there are many variations in the specific chemistry of Li-Ion batteries, additional classifications may be necessary to determine if the battery is a hazardous waste. It is the responsibility of the generator to make this determination. Generally, under federal and state law, sealed, Li-Ion batteries may be considered dry cell batteries and therefore may be managed as a universal waste; damaged or leaking Li-Ion batteries may be regulated as hazardous waste under federal and state regulations.